

BEAMS & TIMBER

MADE BETTER - LOOKS SMARTER - LASTS LONGER



**PRODUCT
CATALOGUE**

Celebrating 20+ years helping Kiwi property owners build something they're genuinely proud of.

**Premium Interlock Fencing, Gates, Bollards & Custom Timber.
Made Better, Looks Smarter, Lasts Longer.**



BTD INTERLOCK POST & RAIL FENCING



HIGH GRADE TIMBER GATES



SQUARE & ROUND TIMBER BOLLARDS



CUSTOM TIMBER



Complement the overall aesthetic with painting or staining
150mm x 150mm / 150mm x 50mm x 1.8m / 0.9m



Great example of feature background planting
150mm x 150mm / 150mm x 50mm x 2.0m / 1.2m



Create flowing curves and lines
150mm x 150mm / 150mm x 50mm x 2.0m / 1.2m

WHY CHOOSE US?



BUILT BETTER FROM THE START

We reject around 20% of the timber we start with. Only the best makes it to your property – straight, stable, and visually superior timber you can see the difference in immediately. That's not a marketing line. It's just what it takes to do this right.



THE NO WORRIES GUARANTEE

15-year structural integrity guarantee. 3-year workmanship guarantee. Delivery accuracy guarantee. If anything isn't right, we sort it – no forms, no runaround. We stand behind every product 100%, long after it's installed.



3-STAGE QUALITY CONTROL

Every piece of timber goes through our 3-stage QC process: selective sourcing and air drying, machining and full treatment encapsulation, and a final pre-delivery check by a separate team member. Crafted with care. Checked at every step. Built to last.



STRAIGHT-UP EXPERT ADVICE

We've been doing this for 20+ years. We'll help you choose the right system, get your quote sorted fast, and answer any questions plainly. No jargon, no upselling – just honest advice from people who know timber inside out.



100% NZ-GROWN, KIWI-OWNED

All our timber is sustainably sourced from NZ pruned logs, milled by us, and controlled from start to finish. We're proudly 100% Kiwi-owned – and the quality of what we grow right here is hard to beat.



5-STAR EVERY TIME

If your experience with us is anything less than 5-star, we'll do whatever it takes to make it right. That's not a slogan – it's a promise backed by hundreds of happy customers and a 5.0 Google rating.

Made Better - Looks Smarter - Lasts Longer.
Backed by our No Worries Guarantee.

BACKED BY OUR **NO WORRIES GUARANTEE**

PROUDLY MILLED. EXPERTLY CRAFTED. GUARANTEED TO PERFORM.

At Beams & Timber, we stand behind our Interlock Fencing, gates, bollards and custom timber solutions with an industry-leading guarantee, ensuring your investment delivers lasting value.

15-YEAR STRUCTURAL INTEGRITY GUARANTEE

Our **H3.2**, **H4** and **H5** treated timber is guaranteed to remain sound for 15 years from purchase, free from:

- Rot
- Fungal decay
- Termite or borer attack.

Condition: Products must be installed and maintained per recommended guidelines

3-YEAR WORKMANSHIP & MILLING GUARANTEE

We guarantee precision in milling, machining, rebating, and pre-cutting. If any product is defective due to workmanship or incorrect sizing, we'll replace or rectify it at no cost within 3 years.

TIMBER QUALITY GUARANTEE

All timber is hand-selected from pruned sustainably grown NZ logs. We remove approximately 20% of the timber we start with leaving you with only the best. Other companies will think we have lost our mind, offering the below.

We guarantee:

- Minimal twisting or warping
- No significant surface damage / defects or structural weakness

If any do slip through, we'll replace them - simply supply a photo of the issue.

DELIVERY & ORDER ACCURACY GUARANTEE

We take care to ensure your order is complete, correctly packed and arrives in excellent condition.

If there's an issue with freight damage, missing components or packing errors - we'll put it right, fast and at our cost.

CUSTOMER SATISFACTION COMMITMENT

We want you to be totally stoked with the end result. If your experience is less than 5-star, contact us and we'll take every step to make it right - whether through replacement, support or expert advice.

IMPORTANT NOTES

Coverage requires adherence to our installation and maintenance guidelines.

Natural timber characteristics, such as surface checking or colour changes are expected and not considered defects.

This guarantee applies to the original purchaser with proof of purchase.

Custom timber solutions are covered under the terms, provided they meet specific treatment levels (**H3.2**, **H4** or **H5**).

Some minor movement in timber is to be expected being a natural product, i.e. minimal is defined for a 2 meter rail as no more than 10mm deviation in the middle from a flat surface.

Minimal twisting or warping guarantee does not apply to rails longer than 2m.



We don't just sell timber - We stand behind it.

3 STAGE QUALITY CONTROL PROCESS

At Beams & Timber Direct, we transform raw NZ pruned logs into premium timber you can rely on through our rigorous **3-Stage Quality Control Process**. Each stage is designed to maximise stability, durability, and visual appeal – backed by over **20+ years of Kiwi craftsmanship** and our **No Worries Guarantee**.

Timber movement is a real concern – twisting, warping and checking can all occur if timber isn't handled properly. We take this seriously. Most timber movement happens during **changes in moisture content**, which is why our process focuses heavily on a **gentle air drying, multiple inspection points, and selective rejection**.

The result? We reject **over 20% of the timber we start with**, so only the best makes it to your project – a level of quality control that is **well beyond industry norms**.

Stage 1: Selective Sourcing, Milling & Pre-Treatment Drying

What We Do:

- Selectively source sustainably grown, pruned NZ logs chosen for density and stability
- Mill all timber in-house for full control over quality
- Air-dry timber under weights to help set the grain and reduce movement
- Reject any timber that doesn't meet our standards at this early stage

Why It Works: Starting with premium raw material and using a controlled, gentle drying process dramatically reduces issues later. Weighted air drying helps stabilise the timber and minimise twisting, warping and excessive checking.

Result: Only high-quality, visually superior timber progresses – with improved stability and consistency from the very start.

Stage 2: Machining, Finishing & Timber Treatment

What We Do:

- Complete all machining and finishing before treatment
- Timber is inspected multiple times during machining, with any sub-standard material rejected
- Apply full H3.2 / H4 / H5 treatment after machining for complete encapsulation

Why It Works: By machining first, we ensure **full treatment coverage** across every surface – delivering superior resistance to rot, decay and pests. Multiple checks during this stage ensure only the best timber moves forward.

Result: Fully machined, fully treated timber – clean, consistent, and ready for final validation.



Stage 3: Post-Treatment Re-Drying, Packing & Order Accuracy

What We Do:

- Selected products (such as fencing rails) undergo **post-treatment re-drying** to identify timber prone to movement
- Conduct a final quality control inspection before packing
- Orders are independently checked by a separate staff member for accuracy

Why It Works: This final stage catches any last-minute movement issues and ensures your order arrives exactly as expected – backed by our Delivery & Order Accuracy Guarantee and No Worries after-sales support.

Result: Defect-free timber, packed correctly – ready for a smooth installation and long-term performance.

Why This Matters

Craftsmanship You Can Trust: Each stage builds on the last. With over **20% of timber rejected** and drawing on **80+ years of combined staff experience**, only premium material reaches your property.

Peace of Mind: Our process directly supports our **No Worries Guarantee**, covering structural integrity, workmanship, and quality – long after installation.



Crafted with Care. Checked at Every Step. Built to Last.

THE BEAMS & TIMBER PROCESS

Below is a clear overview of our full Beams & Timber process – from the careful sourcing of logs through to delivery and after-sales support. This gives you a general understanding of how your order moves from concept to completion, along with the typical time frames involved in each stage.

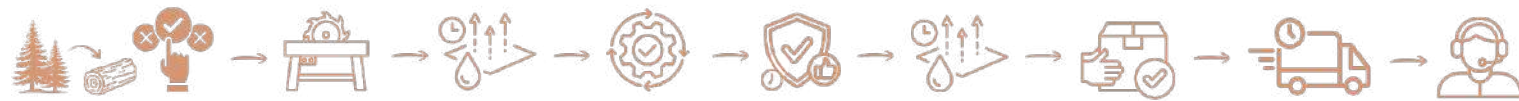

We carry out strict quality control checks at every stage – drying, milling, machining, treatment, and post-treatment re-drying – to ensure our timber meets the highest standard before it ever reaches you. Each phase takes a reasonable and carefully managed amount of time to achieve the quality we are known for.

For more detailed or product-specific information, please contact us – we're always happy to guide you through what applies to your order.

SELECTIVE SOURCING OF LOGS

We don't mill just any logs – we select only the best Radiata Pine from trusted New Zealand suppliers.

Each log must meet strict specifications for size, length, grade, and age, ensuring strength and stability.

Location also matters: logs grown in warmer northern climates tend to have tighter growth rings and denser timber, leading to a stronger, more stable product.

Whenever possible, we source from local, smaller-scale growers rather than large commercial operations, supporting sustainable forestry and community suppliers.

Timeline: 1 - 2 Weeks (varies with availability)



IN-HOUSE MILLING FROM PRUNED LOGS

We mill all our timber in-house from pruned logs – something few others in the industry do. Pruned logs produce clearer, higher-grade timber with fewer knots, which means:

- ✓ Less twisting and warping
- ✓ Fewer defects or knot holes
- ✓ A smoother, cleaner appearance

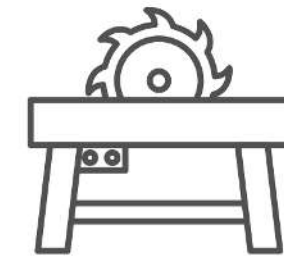

Controlling this process internally allows us to guarantee consistency and exceptional quality in every piece.

Timeline: 1 - 2 Weeks (or longer depending on quantities)

GENTLE TIMBER DRYING

Drying, or "seasoning", removes excess moisture from timber to improve stability, strength, and longevity.

While kiln drying is often seen as the industry standard, we've found that air drying produces superior results when done correctly.

It's slower – but gentler – reducing checking (surface cracks) and timber movement.

We stack, weigh, and cover our timber properly to promote even drying. As the saying goes:

Good things take time – and well-dried timber is worth the wait.



Timeline: 4 - 12 Weeks (weather-dependent, timber size etc., can be sped up with the kiln)

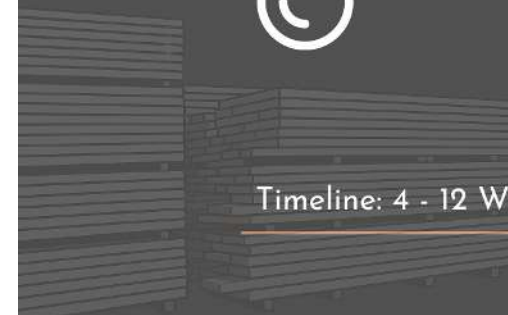

PROCESSING & MACHINING

Once the timber reaches the right moisture level, we begin processing it for your specific application.

Our team selects the best boards that meet our high quality control standards, and machines the timber to precise dimensions before treatment

This pre-treatment machining ensures **the entire timber surface is encapsulated** during treatment, protecting it thoroughly and extending its lifespan.



Timeline: 1 - 2 Weeks

TIMBER TREATMENT



After machining, we send the timber for **treatment** – most commonly to **H3.2, H4, or H5** standards depending on its intended use.

The timber is treated in high-pressure cylinders, forcing protective chemicals deep into the cellular structure.

This process guards against decay, insects, and fungi, ensuring durability and long-term performance.

Timeline: 1 - 2 Weeks

RE-DRYING

Some products undergo a second drying phase after treatment to achieve optimal moisture balance.

This step further reduces shrinkage and warping, minimizes surface checking, and ensures consistent sizing (especially important for interlock fencing rails).

Each batch is re-inspected during this stage – any piece that doesn't meet our standards is rejected.

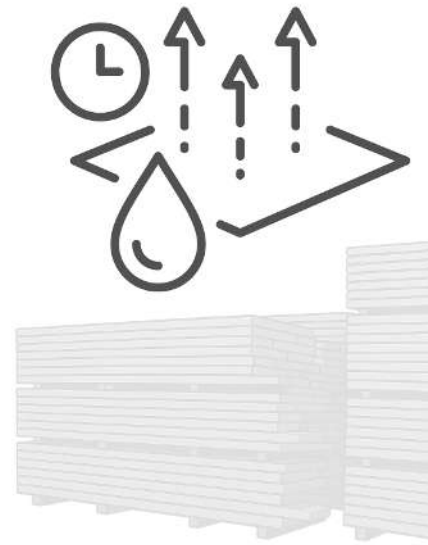

Timeline: 2 - 6 Weeks

PACKING & FINAL QUALITY CHECK



When all components for your order are complete, we carefully pack and assemble your order for collection or freight.

Each order goes through a final visual inspection for quality and accuracy.

A secondary check by another team member to minimize packing errors and ensure everything is securely prepared for transport.

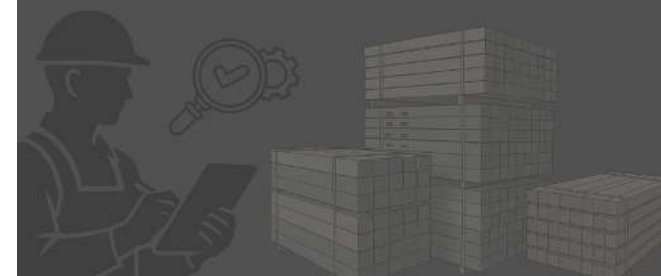

Timeline: 1 Week

FREIGHT & DELIVERY

If your order requires delivery, we'll coordinate with one of our trusted freight partners.

Once your order is collected, we'll notify you immediately with the tracking details and estimated delivery timeframe.

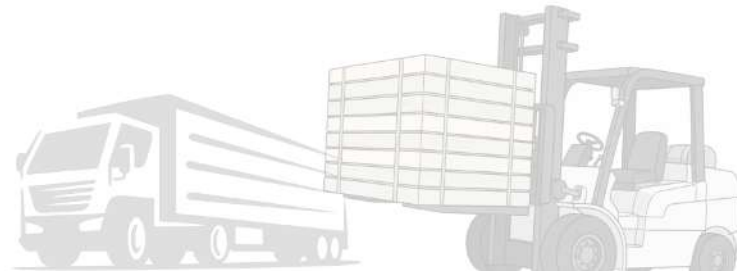

Timeline: 1 Week



AFTER-SALES SUPPORT

Our relationship doesn't end when your order leaves the yard.

We stand by our products and are always here for:

- ✓ Guidance on installation, finishing, or maintenance.
- ✓ Quick resolution of any concerns or defects.
- ✓ Follow-up checks to ensure everything performs as expected.



... At Beams & Timber, we genuinely care about your satisfaction and the success of your project – from the first log to the final post.

Timeline: Ongoing - Contact Anytime



THINGS TO CONSIDER WHEN CHOOSING YOUR FENCE

PURPOSE

It's worth taking the time to consider your goals for the fence. Is it for aesthetic enhancement? Do you need to contain pets, animals, or livestock? Is it to define your boundary, meet security requirements, or create privacy? Do you want to make a statement with your entrance way? Understanding what you want from your fence is the first step to getting something you'll still love looking at 15 years from now.

STYLE AND DESIGN

Consider the architectural style of your home and the surrounding landscape when selecting a fence style to complement the overall aesthetic. Our Interlock system is ideal when you want to complement a view or showcase beautiful landscaping – not block it. It adds an elevated elegance to the classic post-and-rail look. Nothing finishes a property quite like a fence line that works with it.

HEIGHT AND REGULATIONS

Check local regulations regarding fence height, setback requirements, and any other restrictions that may apply. Our Interlock Post and Rail fencing comes in a variety of heights, from 0.6m to 1.2m above ground in our standard range. We also offer custom options to provide endless possibilities. Contact us to discuss your ideas and requirements.

COST VS VALUE

Fencing is a one-time investment – which makes the quality of the timber you choose matter more than most people realise. Cheap timber might save money upfront, but warping, rot, and early replacement wipe out that saving fast. Our Interlock fencing is built from timber we've already rejected 20%+ of, and it's backed by a 15-year structural guarantee. That's what genuine long-term value looks like.

MATERIALS

All our Interlock fencing is milled in-house from sustainably grown, pruned NZ Radiata Pine – chosen for its density, stability, and clean, straight appearance. We machine, treat, and inspect every piece ourselves, giving you a consistent, premium result every time. Natural, low-maintenance, and built to handle NZ's toughest conditions –including the ones that destroy cheap timber fast.

INTERLOCK FENCING FEATURES

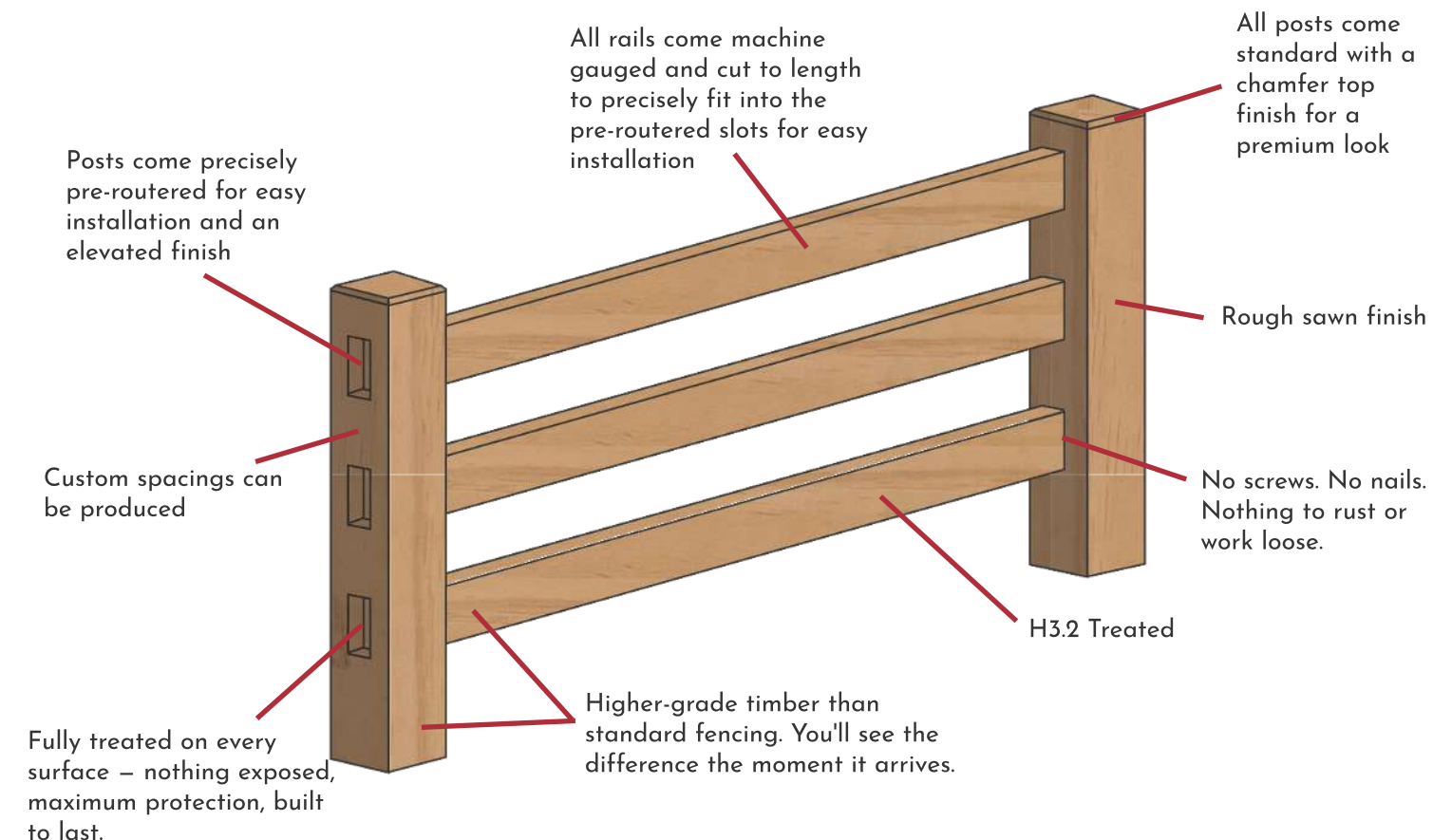

BTD POST & RAIL INTERLOCK FENCING OPTIONS

POST SIZE

The post size sets the tone for your whole fence line. Go smaller for clean and elegant. Go bigger for robust and statement-making. Either way, every post is machined and fully treated before it leaves us – nothing exposed, completely protected.

See our post sizes below, available in lengths up to 6m. Consider the aesthetic you want: simple and elegant with smaller posts, or robust and statement-making with larger posts. Additionally, consider if you need larger posts for your entrance or to hang gates.

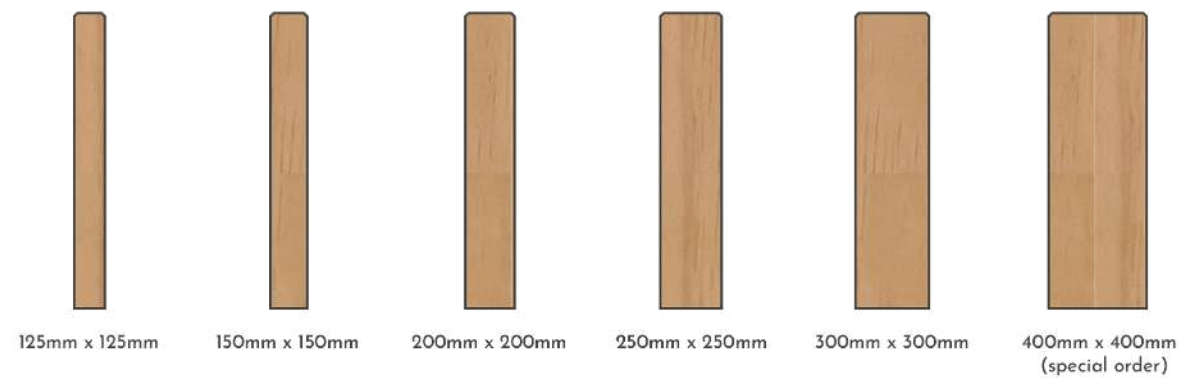

RAIL SIZE

Most fencing suppliers use the cheapest rails they can source. Ours are a grade higher – and once you see them alongside a standard rail, you'll understand why.

We recommend using rail lengths no longer than two meters to minimise issues with twisting, bending, or warping, and to achieve a nicely proportioned look, avoiding a stretched-out appearance.

The 150mm x 50mm rails are machine-gauged on all four sides to fit precisely into the pre-routed slots in the posts. The 200mm x 50mm rails are machined on three sides, allowing for a rough sawn finish on the front, providing a more rustic look when used with larger posts.

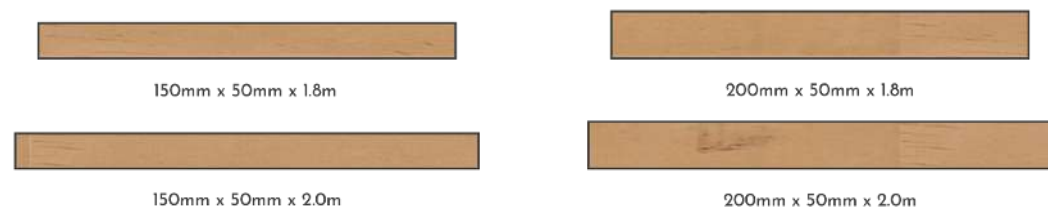

Our fencing is available in 1-rail, 2-rail, 3-rail, and 4-rail options, making our system versatile for a wide variety of applications. The different rail configurations cater to diverse needs.

The 1-rail system serves as a low barrier, ideal for parks and reserves; the 2-rail system provides a more pronounced barrier while maintaining excellent visibility; the classic and stylish 3-rail system is multipurpose; and the 4-rail system is perfect for creating a safe enclosure for pets, animals, livestock or our most pronounced property fence line.

These are just a few examples of the various applications across our range. You can find the specifications for each option at the end of our Interlock system section.

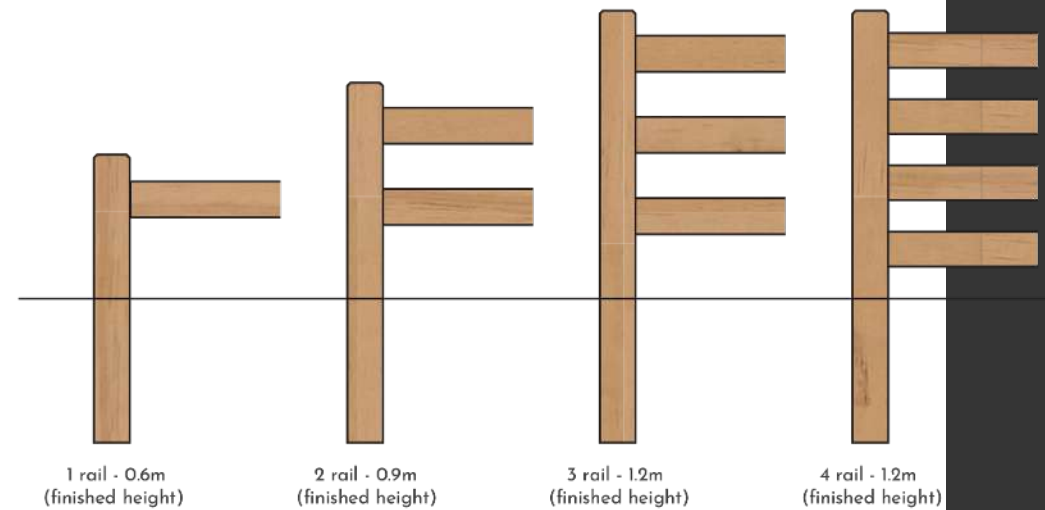

Our pre-routed post types allow for any fence layout you can imagine. With the flexibility for rails to fit into the pre-routed slots at a wide variety of angles. Changes in direction or variations in ground elevation or slopes can be handled with ease.

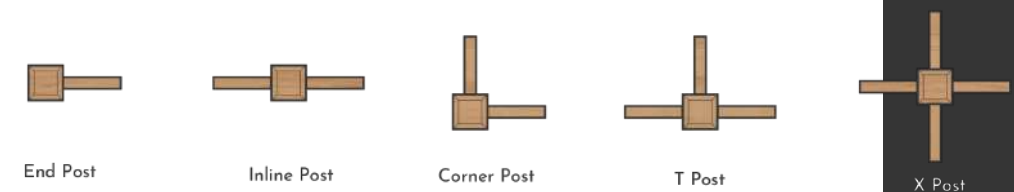

4 RAIL SYSTEM



The robust, stock-safe fence line that still looks the part.

Matamata - full class running inside & outside the property
150mm x 150mm / 150mm x 50mm x 2.0m / 1.2m



The four rail system is great for pets & stock
125mm x 125mm / 150mm x 50mm x 2.0m / 1.2m



Cambridge Stud - Custom four rail
150mm x 150mm / 150mm x 50mm x 1.8m / 1.5m

Four rails means maximum coverage – our most substantial system. Designed to contain livestock, animals, and pets without compromising on looks.

The 200mm x 50mm rails give extra height for larger animals.

It's the fence that holds everything in and still turns heads from the road.

3 RAIL SYSTEM

An elevated classic to set your property apart



St Kilda, Cambridge - stylish & timeless in white
150mm x 150mm / 150mm x 50mm x 2.0m / 1.2m

Our three-rail system is the most popular in our range.

It offers the classic post-and-rail look with an elevated finish, thanks to our higher-grade timber, finishing detail, and interlocking system.

Add a wire under the bottom rail and it becomes stock or pet safe too – no separate fence needed.



Warkworth Showgrounds - robust look with larger
150mm x 150mm / 200mm x 50mm x 1.8m / 1.2m



High Grove, Matamata - awesome finish with planting back drop
150mm x 150mm / 150mm x 50mm x 2.0m / 1.2m

HEAR FROM OUR CUSTOMERS

Don't take our word for it. Here's what Kiwi property owners say after their fence goes in.

GOOGLE REVIEW ★★★★★

We worked with Beams & Timber last year to do a custom fence line for our rural property in Silverdale and they were a pleasure to deal with - very helpful & informative and did their best to cater to our needs and we've ended up with a very unique and impressive entrance way that everyone comments on! We will be using them in future projects.

Straka Construction & Earthmoving LTD

GOOGLE REVIEW ★★★★★

Great product. Took me 2 years to finally order it but the results that it gives our property is superb. I knew from the outset that it was worth it and it was. The neighbourhood loves it as they think it makes everybody look good hence higher values. The team at Beams and Timber were always helpful and patient.

Mylam Sloan



Palliser Downs - integrates well with stone finishes
200mm x 200mm / 200mm x 50mm x 2.0m / 1.5m

GOOGLE REVIEW

★★★★★

We have recently built a new house on a small block and we could not decide what sort of fence to put in. The lovely staff at Beams & Timber were able to give us suggestions and provide us with addresses where we could see completed fences. We went with their recommendations and we could not be happier. A pleasure to work with this company.

Tracy Thompson

GOOGLE REVIEW ★★★★★

Our new fence is absolutely fabulous, it just finishes the property off. The best fencing system around in our opinion. The team at Beams and Timber could not have been more helpful. Graeme Ross (Matamata) put the fence up and did a great job at a reasonable price.

Julie Earl



Looks impressive in a long run
150mm x 150mm / 150mm x 50mm x 2.0m / 1.2m

GOOGLE REVIEW ★★★★★

The team at Beams and Timber were great to deal with, advise was great also delivery and supplying a fantastic product. We did 200 metres of three rail and used one of their suggested installers. Best move I ever did, 200 metres dead straight and correctly installed. Highly recommend this company.

Gerry Watkinson

just a few of our many reviews...

2 RAIL SYSTEM



Stunning in the morning sun
125mm x 125mm / 150mm x 50mm x 2.0m / 0.9m

Keep your views.
Define your
boundary.



Nice and Sturdy using bigger posts and rails
250mm x 250mm / 200mm x 50mm x 2.0m / 0.9m



Also looks great in residential settings
150mm x 150mm / 150mm x 50mm x 2.0m / 0.9m

Our two-rail system is the second most popular in our range.

A lower-profile fence that keeps things clean and open – ideal for properties with views worth preserving.

A clean minimalistic look that will have your neighbours green with envy.



Hamilton International Airport - robust low barrier
200mm x 200mm / 200mm x 50mm x 2.0m / 0.6m



Glenview - ideal separation between footpath and shared driveway
150mm x 150mm / 200mm x 50mm x 2.0m / 0.6m

Clean, low-profile,
and easy on the
budget.

Our 1-rail system is the lowest profile fence and most cost effective in our range. Also the fastest and easiest to install.

It's perfect for car parks, recreational areas, and commercial use.

Keeps vehicles and cyclists out. Easy step over for pedestrians. Clearly defines your boundary – fast to install and simple to maintain.

1 RAIL SYSTEM



STANDARD SPECIFICATIONS

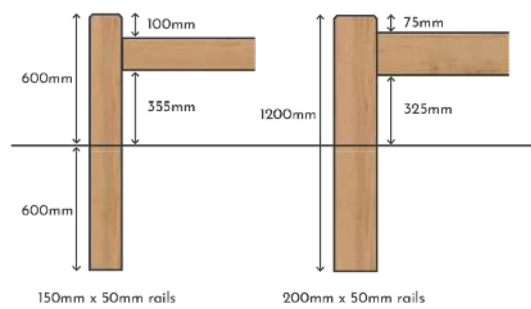
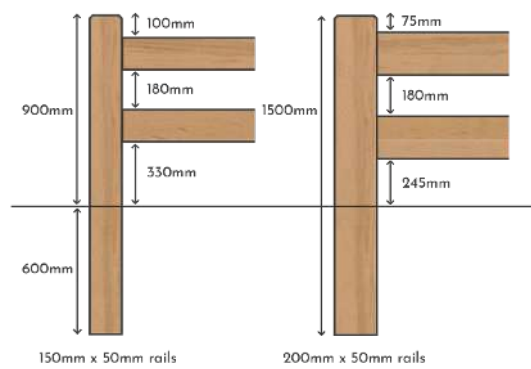
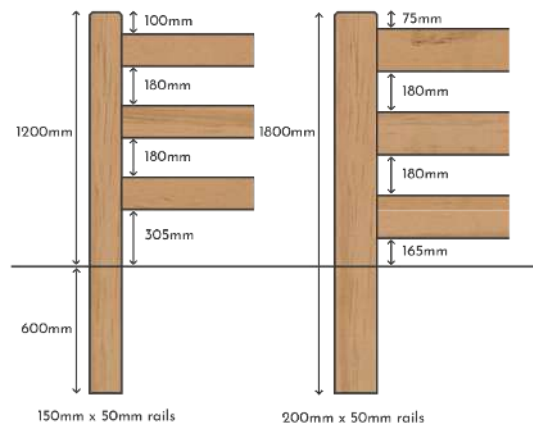
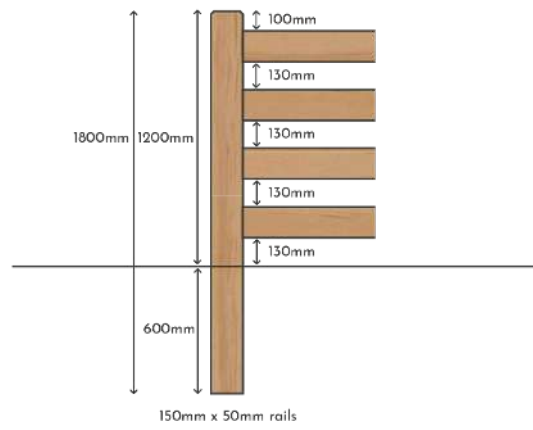

Custom spacing available - talk with us today!



GOOGLE REVIEW ★★★★★

We required a new front boundary fence on our lifestyle block in South East Auckland and decided a timber interlocking fence would probably look the best. I started corresponding with Helen at Beams and Timber and with her help we decided on the fence we wanted. It was manufactured by them in the time frame promised.

I installed it myself and the job was made easier because of the high quality of the timber supplied. The beams and posts were all perfectly straight and the slots in the posts were cut out to perfectly fit the rails. I over ordered a few items and Pete was happy for me to return them.

We couldn't be happier with the end result and would thoroughly recommend Beams and Timber to anyone wanting a top quality fence.

Murray Draper

CASE STUDY

Roger first reached out to us in late 2019 regarding an upcoming subdivision in Matamata. Having previously used our INTERLOCK® fencing system for another subdivision, Blackwood Park, Roger was already familiar with the quality and durability of our products. The positive feedback he received from customers further reinforced his decision that INTERLOCK® fencing would be the perfect choice for his new project, Highgrove.

The Highgrove subdivision was a collaborative venture between Roger and the Begovich brothers. While the brothers had an existing relationship with another supplier offering a similar product, they needed to carefully evaluate which company would best meet their needs for this premium development.

After visiting both Beams & Timber Direct and the competing supplier, the team ultimately decided that our offering was the superior choice for Highgrove. While the investment cost for our fencing was higher than the competitor's, they recognized the superior quality of our timber and craftsmanship. This aligned perfectly with Highgrove's ethos: *"Highgrove takes its cue from the myriad of trees and groves that now set the stage for the finest in rural residential country living. No expense spared, no detail left out."*



Quality was their top priority, with cost being a secondary consideration. As Roger stated, *"From our research, their quality of timber and the level of finish is unmatched in New Zealand."*

Roger and the Begovich brothers were extremely pleased with their decision. *"Beams & Timber were excellent to deal with and supplied a high-quality product within our desired delivery timeframe. We would highly recommend them to anyone undertaking a subdivision, as their products provide a premium look and feel. We will certainly use them for any future projects."*

Now, a couple of years after installation, the fencing still looks as impressive as ever. Check out these stunning photos showcasing the outstanding Highgrove subdivision.



"From our research, their quality of timber and the level of finish is unmatched in New Zealand."

CUSTOM INTERLOCK



Known as the "Speights" fence after the original customer
150mm x 150mm / 150mm x 50mm x 2.0m / 1.2m



Solid finish variation to our original system
200mm x 200mm / 150mm x 50mm x 2.0m / 1.2m



A truly impressive fence in person
200mm x 200mm / 125mm x 125mm x 2.0m / 1.5m

Let us help you realise your vision

Looking for something unique?

We've built curved fence lines, over-height posts, extra-wide entranceway setups, and designs you won't find in any catalogue.

If you can sketch it, we can probably build it.

Talk with us today about your vision, and we can help make it a reality.

CASE STUDY



It was an absolute pleasure getting to visit the Hallett's property almost 4 years after their install. They have a truly stunning property that has been finished beautifully with our fencing, it really does stand out on their road.

The Halletts originally contacted us in May 2020. They required a stock-proof fence suitable for horses, cattle, sheep, and lambs that was also aesthetically pleasing. After months of research, they found that our Interlock Fencing system met their needs better than any other option"there were several that provided the stock proof side, however none of those options had the aesthetic appeal we were looking for".

They planned to include curves in their fence design. Having used standard post and rail fencing on a previous property, they had experienced issues with rails twisting, warping, and detaching from posts, especially in curved sections. Thus, quality was a top priority for them and they were willing to invest in our superior product..



The fencing was produced within the indicated timeframe, with only one minor delay in one delivery, which was communicated effectively. "The delivery was wellcoordinated, and communication throughout the process was excellent".They hired Fully Fenced for the installation, who did an excellent job. "We were impressed with their innovative techniques and the progress made each day. It was exciting coming home from work each day during the installation and seeing a whole new section completed".

Now, four years after the installation, the fence still looks great. "We are pleased we made the investment in our property and spent the extra to get the quality of your timber and product. It's really showing through in how well the fence is aging. I'm sure we will save money in the long run.



"Our overall experience with Beams and Timber was fantastic. Great service, communication, and delivery of a quality product as promised. We would highly recommend Beams and Timber to others."

BTD GATES

Built to match.
Built to last.



Matakana gate looking sharp in stain finish
150mm x 150mm / 200mm x 50mm x 2.0m / 0.9m

Our gates are made to order –
same high-grade Radiata Pine,
same 3-stage QC process, same No
Worries Guarantee.

Whether you're completing a fence
line or creating a statement
entranceway, every gate is built to
match and built to last.

From pedestrian gates to full double
sets – custom made to your width,
height, and style.

Precisely manufactured
to your requirements



Waiheke gate suits just about any fence
250mm x 250mm / 200mm x 50mm x 2.0m / 0.9m



Classic look with the Russell gate
125mm x 125mm / 150mm x 50mm x 2.0m / 0.9m

BTD GATE STYLES

All BTD gates are made to order from the same high-grade NZ Radiata Pine as our fencing – treated, inspected, and guaranteed.

Choose a style below, or talk to us about something completely custom.

WAIHEKE

Gate Types Double Gate Set / Single / Pedestrian
 Timber Size 200 x 25mm
 Length 1200 - 2400mm
 Height 1100mm

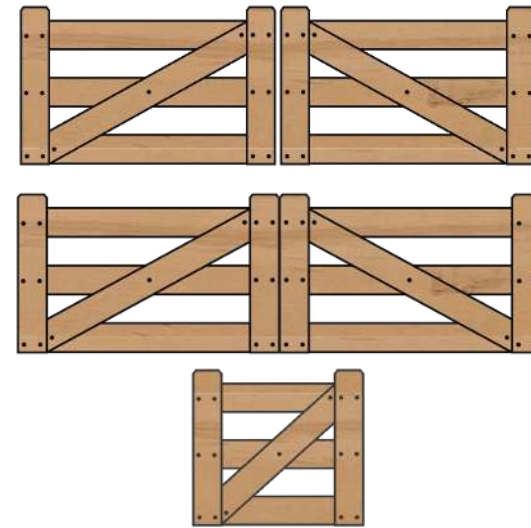

RUSSELL

Gate Types Double Gate Set / Single / Pedestrian
 Timber Size 150 x 25mm
 Length 1200 - 4200mm
 Height 1100mm

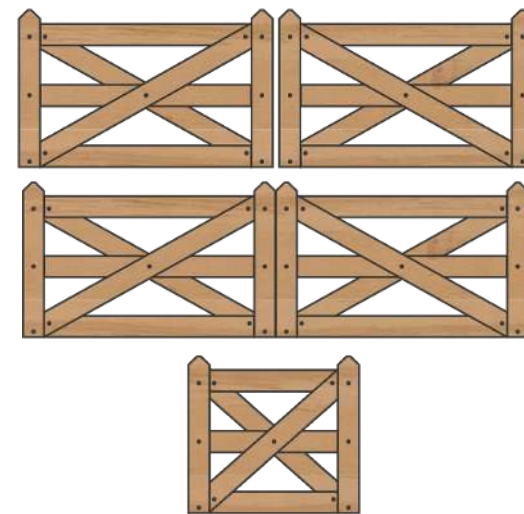

PAIHIA

Gate Types Double Gate Set / Single / Pedestrian
 Timber Size 150 x 25mm
 Length 1200 - 4200mm
 Height 800mm

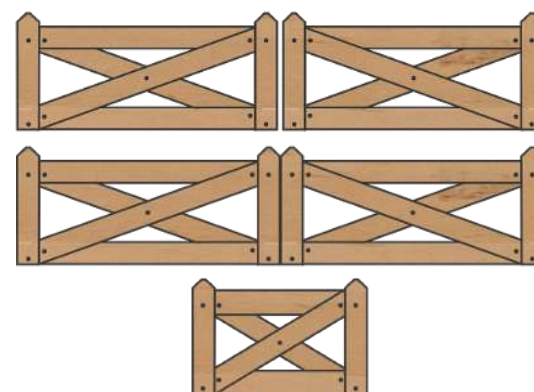

MATAKANA

Gate Types Double Gate Set / Single Gate / Pedestrian Gate
 Timber Size 200 x 25mm
 Length 1200 - 2400mm
 Height 1100mm

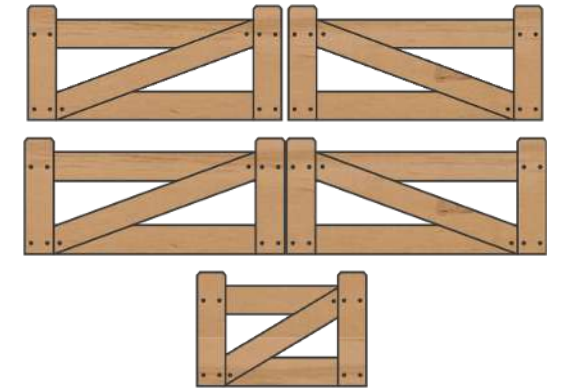

CHRISTCHURCH

Gate Types Double Gate Set / Single / Pedestrian
 Timber Size 150 x 25mm
 Length 1200 - 4200mm
 Height 1100mm

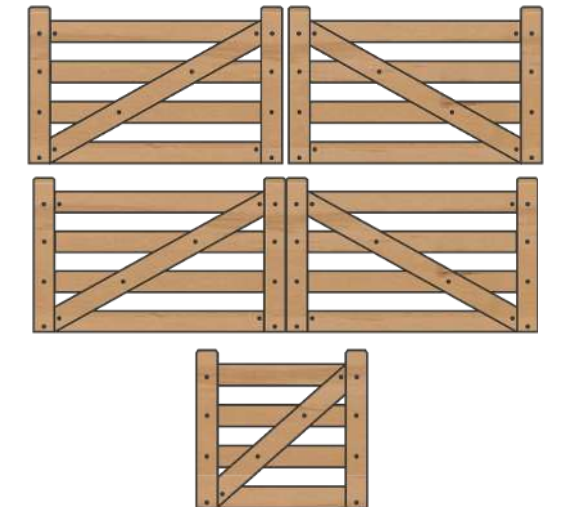

Satisfied customers become successful partners!
 Straka Construction & Earthmoving LTD

★★★★★ GOOGLE REVIEW

We worked with BTD last year to do a custom fence line for our rural property in Silverdale, and they were a pleasure to deal with - very helpful & informative, and did their best to cater to our needs, and we've ended up with a very unique and impressive entrance way that everyone comments on! We will be using them in future projects.

Katie Straka

BTD GATE STYLES

NAPIER

Gate Types Single Gate
Timber Size 150 x 25mm
Length 3000 - 4200mm
Height 1100mm

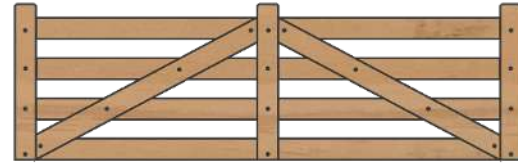

TAUPO

Gate Type Single Gate
Timber Size 150 x 25mm
Length 3000 - 4200mm
Height 1100mm

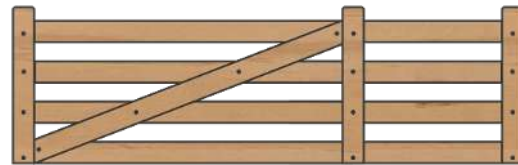

HASTINGS

Gate Type Single Gate
Timber Size 150mm x 25mm
Length 3000 - 4200mm
Height 1100mm

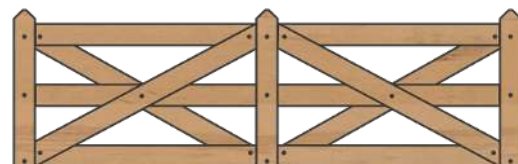

WALTON

Gate Type Single Gate
Timber Size 100 x 25mm
Length 3000 - 4200mm
Height 1100mm

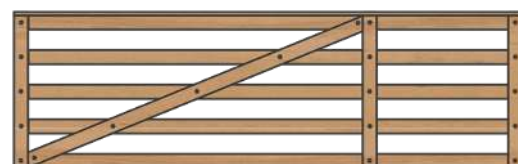

COASTVILLE

Gate Types Double Gate Set
Timber Size 200 x 25mm
Length 2,100 - 3000mm
Height 1100mm (outer), 1400mm (inner)



KERIKERI

Gate Type Double Gate Set
Timber Size 150 x 25mm
Length 2 x 2400 - 3000mm
Height 1700mm (outer) 1100mm (inner)



KINLOCH

Gate Type Double Gate Set
Timber Size 150 x 25mm
Length 2 x 2100 - 2700mm
Height 1400mm (outer) 1100mm (inner)



TAURANGA

Gate Type Double Gate Set
Timber Size 100 x 25mm
Length 2 x 2100 / 2400mm
Height 1500mm (outer) 1100mm (inner)



CROMWELL

Gate Type Double Gate Set
Timber Size 100 x 25mm
Length 2 x 2100 / 2400mm
Height 1500mm (outer) 1100mm (inner)



GATE HARDWARE



STRAP HINGES FOR 3" GATE

Finish Zinc / Epoxy Black
 Sizes M20 x 300 / 375mm



SCREW GUDGEONS SHORT PIN

Finish Zinc / Epoxy Black
 Sizes M20 x 100mm



THROUGH POST GUDGEON

Finish Zinc / Epoxy Black
 Sizes M20 x 250 / 300 / 350mm



THROW OVER LATCHES

Finish Zinc / Epoxy Black
 Sizes 75mm



LOCK THROUGH GUDGEON

Finish Zinc / Epoxy Black
 Sizes M20 x 250 / 300 / 350mm



LOCKABLE DROP BOLT

Finish Hot Dip Galv
 Sizes M12 x 300



SCREW GUDGEONS LONG PIN

Finish Zinc / Epoxy Black
 Sizes M20 x 100mm



LATCH

Finish
 Sizes



Great for businesses to make a strong first impression
250mm x 250mm / 150mm x 50mm x 2.0m / 1.2m

Your entrance way is the first thing people see. Make it count.



Stand out with super sized 400mm x 400mm high top posts
150mm x 150mm / 150mm x 50mm x 2.0m / 1.2m



Looking dapper lining the longer driveway
150mm x 150mm / 200mm x 50mm x 2.0m / 0.6m

Combine our fencing with larger statement posts (high top options available) and a set of matching gates – manufactured by us or sourced to complement.

We can design the layout and connect you with an installer who knows our product.

Your entrance way sets the tone for everything inside your property.



Trusted by
councils, airports,
and property
owners across NZ.

From Hamilton International Airport to beachfront reserves – our bollards are the go-to for councils and commercial operators who need vehicle control without an eyesore.

High-grade NZ Radiata Pine. Rough sawn or machine gauged. Square or round. Built to the same standard as everything else we make.

Choose from our standard range for fastest delivery, or talk to us about custom.



BTD BOLLARDS

BOLLARD LENGTHS

Below are the standard lengths we offer, we can also produce to any custom specifications required. The most popular length is 1200mm, followed by 900mm and 1500mm. There is no set in-ground depth for bollards; we recommend setting 1/3 to 1/2 of the bollard in the ground.

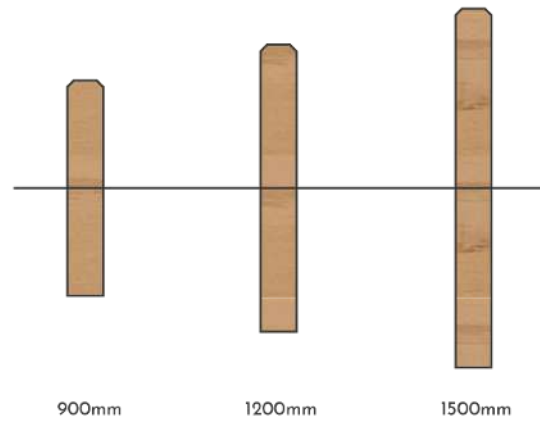

SQUARE BOLLARD SIZES

We have a good range of sizes available below. Our 150mm x 150mm size with a machine gauged finish is the most widely used for bollards.



ROUND BOLLARD SIZES

The size options are shown below for uni-diameter bollards.



SQUARE BOLLARD SPECIFICATIONS

There are endless options for the look and finish of timber bollards. Below are our standard top profile and detail finish options that we can produce. Holes for rope or chain can also be added to any of our bollard variations. We can custom-make nearly any bollard, although there are setup fees for variations from our standard specifications shown below.

For the fastest delivery and best value, we recommend choosing from our standard range. Custom styles are available, but they take additional lead time – worth keeping in mind if you're working to a project deadline.

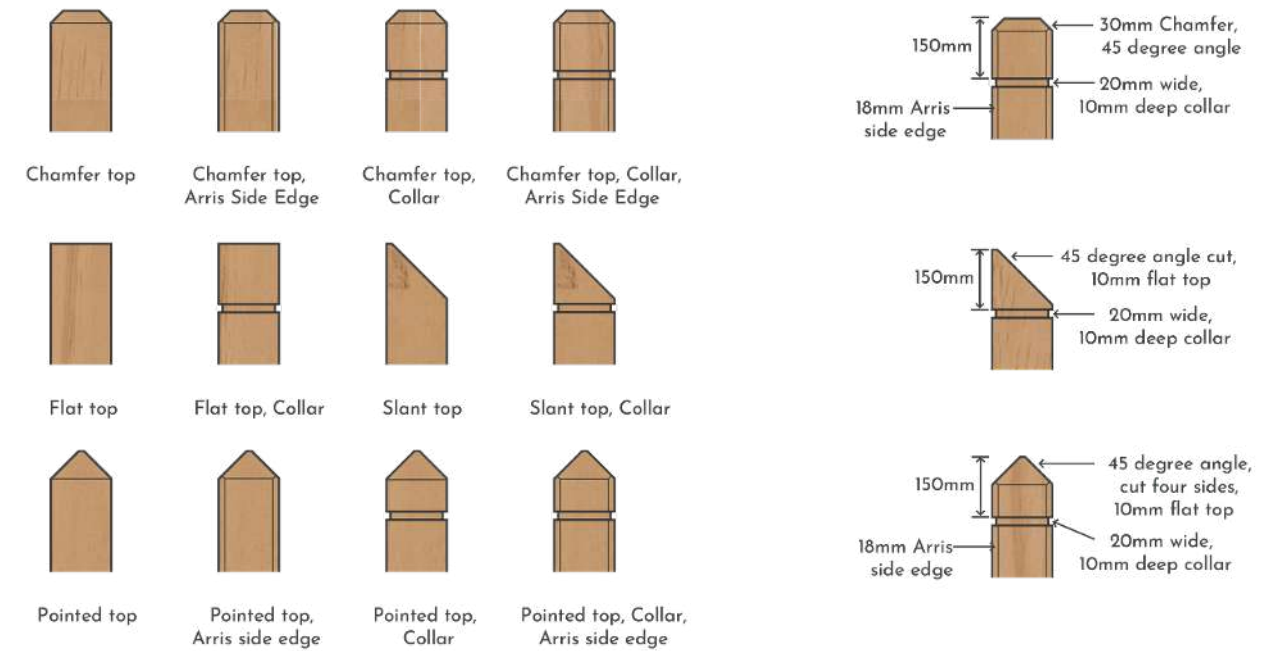

ROUND BOLLARD SPECIFICATIONS

Shown below are the styles and specifications that can be ordered. Slant and bullnose tops can also be manufactured. Holes for rope or chain can be added to any of the available styles. We only hold stock in the standard 150mm dia x 1.2m dome top bollard, all other styles are made to order.

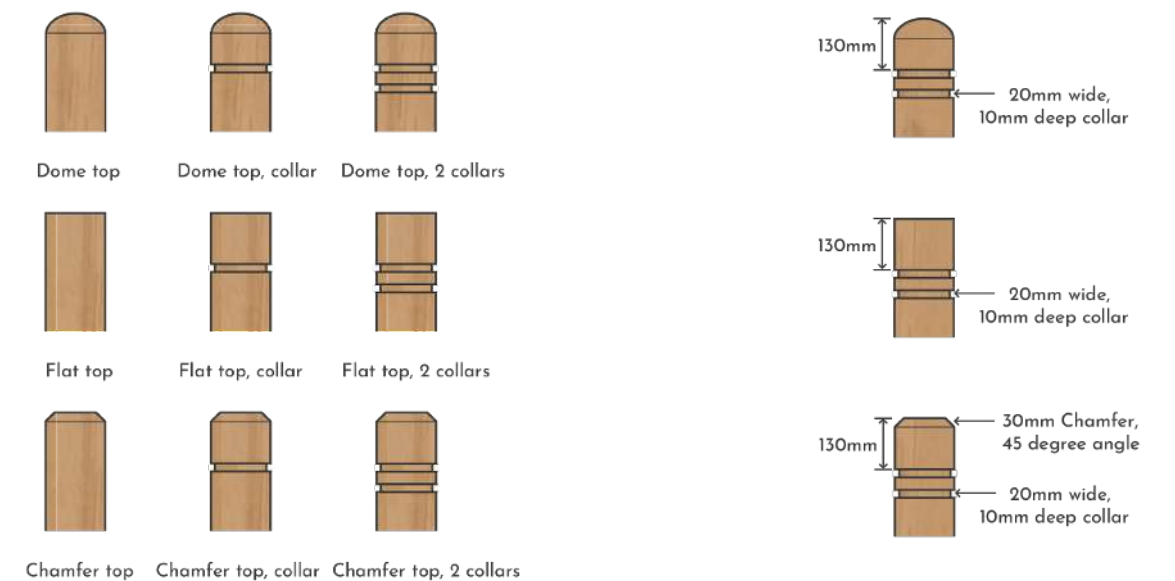

BOLLARD ACCESSORIES



CONCRETE SURROUNDS

We offer pre-cast mowing concrete surrounds for our bollards. These are available in 125mm and 150mm for square bollards, and 150mm and 180 / 200mm for round bollards.



REMOVABLE SLEEVES

Need vehicle access to an area sectioned off with bollards? Our removable sleeves are the perfect solution. Available for 150mm bollards in both round and square, simply concrete in the sleeve, attach the supplied hasp to the bollard, fit it through the slot in the lid, and secure it with a padlock.

CUSTOM TIMBER

Need timber sizes you can't find at a merchant? We mill in-house from pruned NZ logs – which means we can offer sizes, grades, and lengths that most suppliers simply don't stock. H3.2, H4, and H5 treatment options. Large quantities available. Competitive pricing on all grades.

Can't find the size you need in our standard range? We can custom mill from stock for multi-piece orders. Available rough sawn or machine gauged up to 350mm wide and 160mm thickness. H3.2, H4, and H5 treatment options. If you're not sure what you need, call us – we'll work it out.

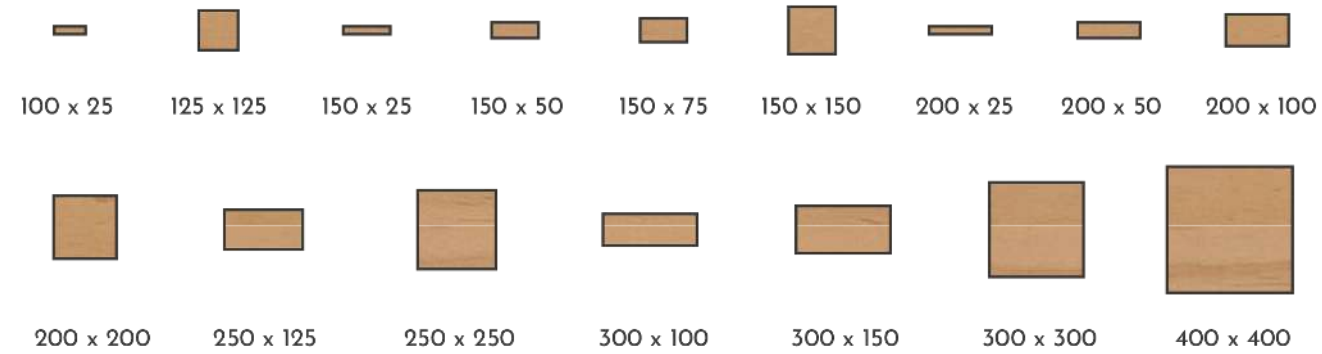



Ready to get started?

Request your free
quote at our website or
call us direct.

We'll have a quote
back to you fast.

 09 236 9916

 www.beamsandtimber.co.nz

 sales@beamsandtimber.co.nz

 34 Bollard Rd., Tuakau 2121, New Zealand